

M81713FP

HIGH VOLTAGE HALF BRIDGE DRIVER

DESCRIPTION

M81713FP is high voltage Power MOSFET and IGBT module driver for half bridge applications.

FEATURES

- FLOATING SUPPLY VOLTAGE 600V
- OUTPUT CURRENT $\pm 500\text{mA}$
- HALF BRIDGE DRIVER
- SINGLE INPUT TYPE
- INTERNALLY SET DEADTIME
- UNDERVOLTAGE LOCKOUT
- SOP-8 PACKAGE

APPLICATIONS

MOSFET and IGBT module inverter driver for PDP, HID lamp, refrigerator, air-conditioner, washing machine, AC-servomotor and general purpose.

PIN CONFIGURATION (TOP VIEW)

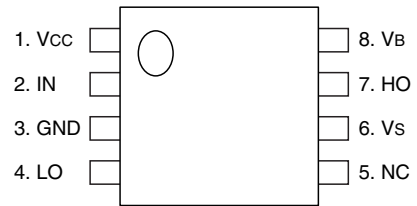

NC:NO CONNECTION

Outline:8P2S

BLOCK DIAGRAM

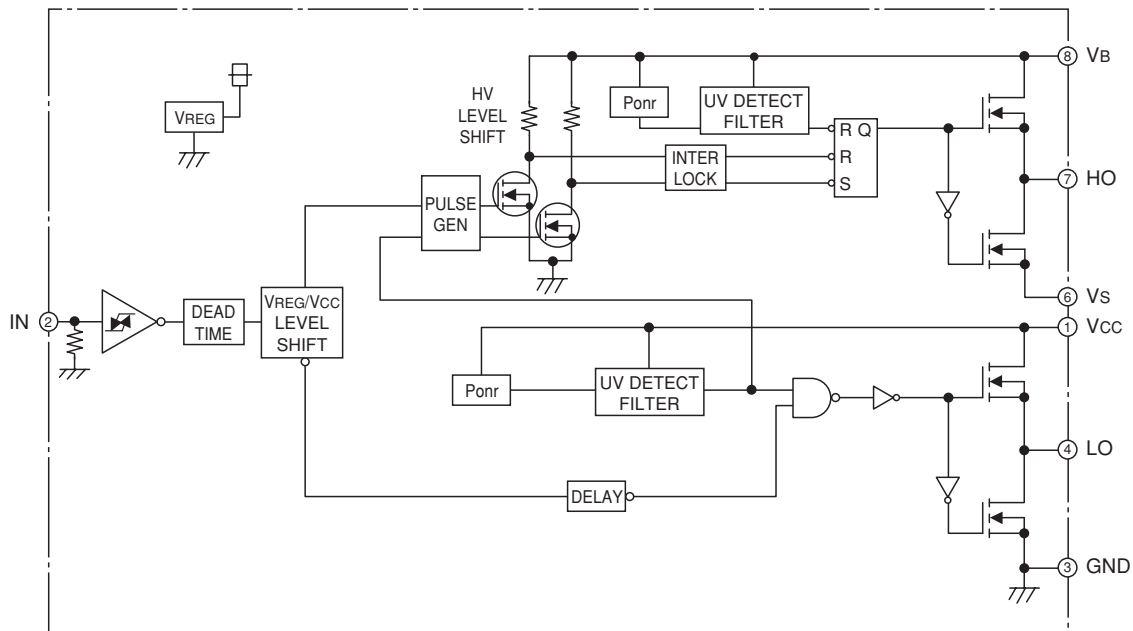

ABSOLUTE MAXIMUM RATINGS (Ta = 25°C unless otherwise specified)

Symbol	Parameter	Test conditions	Ratings	Unit
V _B	High Side Floating Supply Absolute Voltage		-0.5 ~ 624	V
V _S	High Side Floating Supply Offset Voltage		V _B -24 ~ V _B +0.5	V
V _{BS}	High Side Floating Supply Voltage	V _{BS} = V _B -V _S	-0.5 ~ 24	V
V _{HO}	High Side Output Voltage		V _S -0.5 ~ V _B +0.5	V
V _{CC}	Low Side Fixed Supply Voltage		-0.5 ~ 24	V
V _{LO}	Low Side Output Voltage		-0.5 ~ V _{CC} +0.5	V
V _{IN}	Logic Input Voltage		-0.5 ~ V _{CC} +0.5	V
dV _S /dt	Allowable Offset Voltage Transient		±50	V/ns
P _d	Package Power Dissipation	Ta = 25°C, On Board	0.55	W
K θ	Linear Derating Factor	Ta > 25°C, On Board	5.5	mW/°C
R _{th(j-c)}	Junction-Case Thermal Resistance		50	°C/W
T _j	Junction Temperature		-20 ~ 125	°C
T _{opr}	Operation Temperature		-20 ~ 100	°C
T _{stg}	Storage Temperature		-40 ~ 125	°C

RECOMMENDED OPERATING CONDITIONS

Symbol	Parameter	Test conditions	Limits			Unit
			Min.	Typ.	Max.	
V _B	High Side Floating Supply Absolute Voltage		V _S +10	—	V _S +20	V
V _S	High Side Floating Supply Offset Voltage	V _B > 10V	-5	—	500	V
V _{BS}	High Side Floating Supply Voltage	V _{BS} = V _B -V _S	10	—	20	V
V _{HO}	High Side Output Voltage		V _S	—	V _B	V
V _{CC}	Low Side Fixed Supply Voltage		10	—	20	V
V _{LO}	Low Side Output Voltage		0	—	V _{CC}	V
V _{IN}	Logic Input Voltage		0	—	V _{CC}	V

* For proper operation, the device should be used within the recommended conditions.

THERMAL DERATING FACTOR CHARACTERISTIC (MAXIMUM RATING)

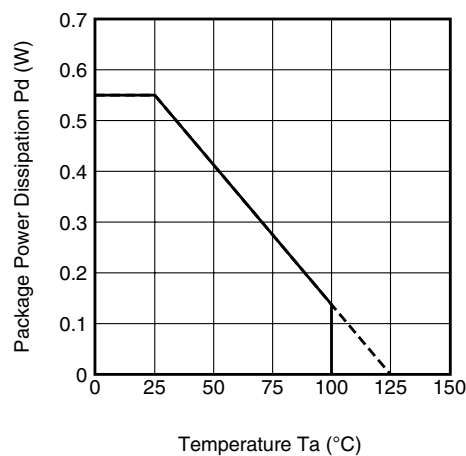

ELECTRICAL CHARACTERISTICS (Ta = 25°C, Vcc = Vbs (= Vb-Vs) = 15V, unless otherwise specified)

Symbol	Parameter	Test conditions	Limits			Unit
			Min.	Typ.*	Max.	
IFS	Floating Supply Leakage Current	Vb = Vs = 600V	—	—	1.0	μA
IBS	Vbs Standby Current	IN = 0V	—	0.2	0.5	mA
ICC	Vcc Standby Current	IN = 0V	0.2	0.5	0.75	mA
VOH	High Level Output Voltage	Io = 0A, LO, HO	13.8	14.4	—	V
VOL	Low Level Output Voltage	Io = 0A, LO, HO	—	—	0.1	V
VIH	High Level Input Threshold Voltage	HIN, LIN	2.1	3.0	4.0	V
VIL	Low Level Input Threshold Voltage	HIN, LIN	0.6	1.5	2.0	V
IiH	High Level Input Bias Current	VIN = 5V	—	25	75	μA
IiL	Low Level Input Bias Current	VIN = 0V	—	—	1	μA
VBSuvr	Vbs Supply UV Reset Voltage		8.0	8.9	9.8	V
VBSuvh	Vbs Supply UV Hysteresis Voltage		0.5	0.7	—	V
tVBSuv	Vbs Supply UV Filter Time		—	7.5	—	μs
VCCuvr	Vcc Supply UV Reset Voltage		8.0	8.9	9.8	V
VCCuvh	Vcc Supply UV Hysteresis Voltage		0.5	0.7	—	V
tVCCuv	Vcc Supply UV Filter Time		—	7.5	—	μs
IOH	Output High Level Short Circuit Pulsed Current	Vo = 0V, PW < 10μs	—	-500	—	mA
IOL	Output Low Level Short Circuit Pulsed Current	Vo = 15V, PW < 10μs	—	500	—	mA
ROH	Output High Level On Resistance	Io = -200mA, ROH = (VOH-Vo)/Io	—	30	—	Ω
ROL	Output Low Level On Resistance	Io = 200mA, ROL = Vo/Io	—	12	—	Ω
tDEAD	Dead Time LO Turn-Off to HO Turn-On & HO Turn-Off to LO Turn-On	CL = 1000pF between HO-Vs, LO-GND	0.5	—	1.00	μs
VPonr	Power On Reset Voltage		—	—	6	V
tPonr(FIL)	Power On Reset Filter Time		300	—	—	ns
tdLH	Turn-On Propagation Delay	CL = 1000pF between HO-Vs, LO-GND	0.6	0.9	1.2	μs
tdHL	Turn-Off Propagation Delay	CL = 1000pF between HO-Vs, LO-GND	0.1	0.15	0.2	μs
trH	High Side Turn-On Rise Time	CL = 1000pF between HO-Vs	—	75	180	ns
tfH	High Side Turn-Off Fall Time	CL = 1000pF between HO-Vs	—	75	180	ns
trL	Low Side Turn-On Rise Time	CL = 1000pF between LO-GND	—	75	180	ns
tfL	Low Side Turn-Off Fall Time	CL = 1000pF between LO-GND	—	75	180	ns

* Typ. is not specified.

INPUT/OUTPUT TIMING DIAGRAM

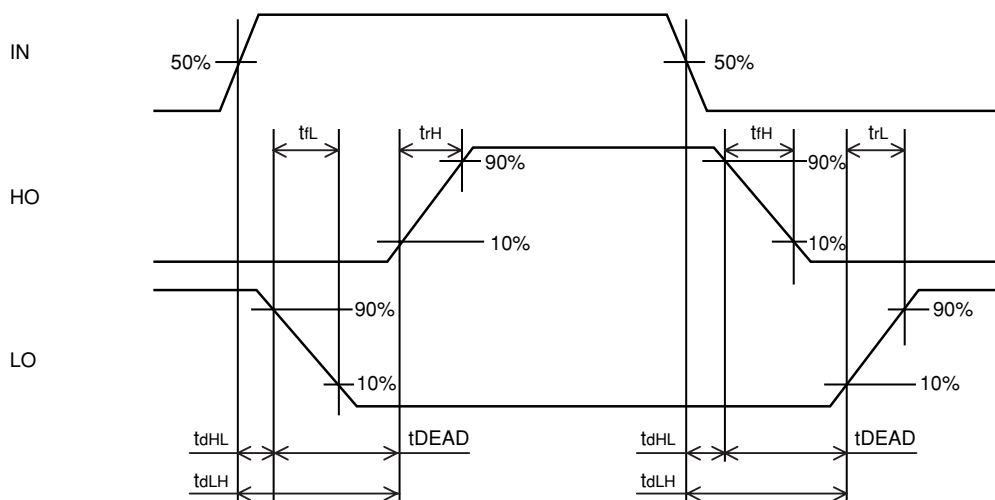

UV SEQUENCE

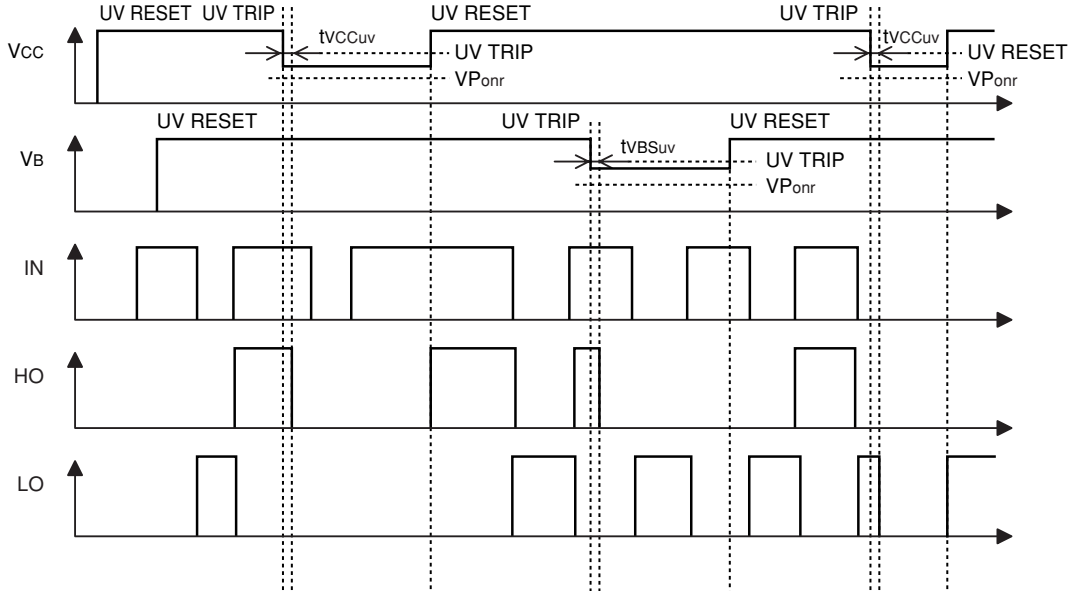

1. Input/Output Logic:

HO has positive logic with reference to IN. LO has negative logic with reference to IN.

2. Logic During UV (Vcc, VBS) Error

Error Signal	HO	LO
UV error (Vcc)	HO outputs "L" Level as long as UV error for Vcc is detected. HO responds to IN if Vcc exceeds Vcc UV reset level.	LO is locked at "L" level as long as UV error for Vcc is detected. After Vcc exceeds Vcc UV reset level, the lock for LO is removed and responds to IN signal.
UV error (VBS)	HO is locked at "L" level as long as UV error for VBS is detected. After VBS exceeds VBS UV reset level, the lock for HO is removed following an "L" state of the IN signal, and then HO responds to the input.	LO is independent of VBS to respond to IN.

* IF UV error for Vcc is detected when HO is in "H" level and the falling speed of Vcc is exceeds 0.03V/μs, the off signal for HO might not be transmitted from low side to high side and then HO stays "H".

3. Allowable Supply Voltage Transient

It is recommended that supplying Vcc firstly and supplying Vbs secondly. In the case of shutting off supply voltage, it is recommended to shut off Vbs firstly and to shut off Vcc secondly. At the time of starting Vcc and VBS, power supply should be increased slowly (below 50V/μs). If it is increased rapidly, output signal (HO or LO) may be "H".

Ponr (Power On Reset) SEQUENCE

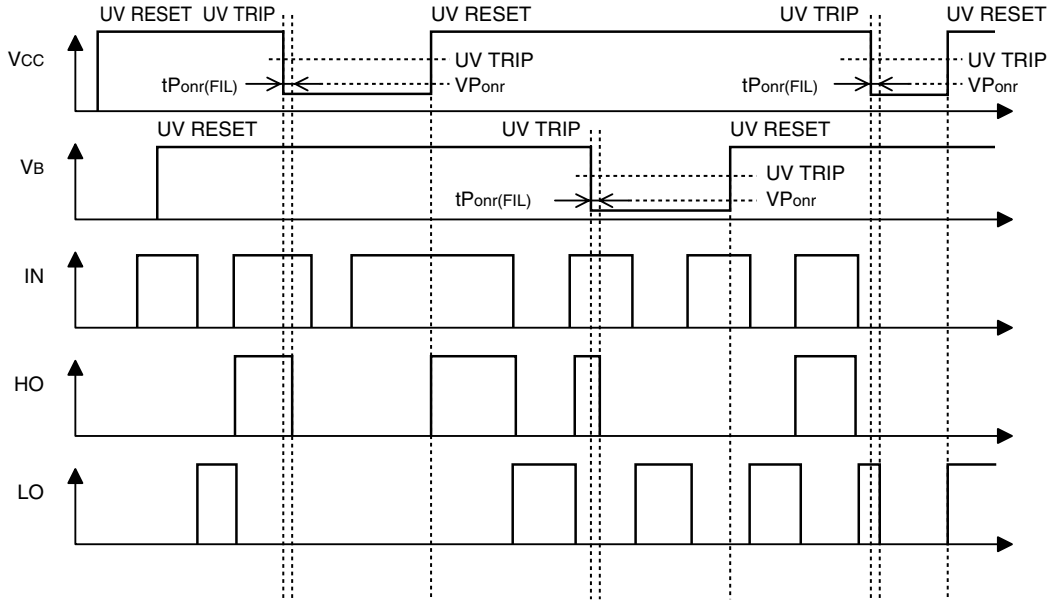

PACKAGE OUTLINE

